

DIEDRICH DRILL

D 70

High Torque, Heavy Duty, All-Purpose Drill Rig



You asked, we delivered.
Big power with a compact footprint.
This drill has been designed from the ground up to provide the ideal combination of all-terrain mobility and drilling performance.
The D-70 boasts an industry leading track system, a robust rotary drive with all the options you need, all connected by a heavy duty frame that is ready to work!
For best in class performance and reliability without compromise, the D-70 will work for you.

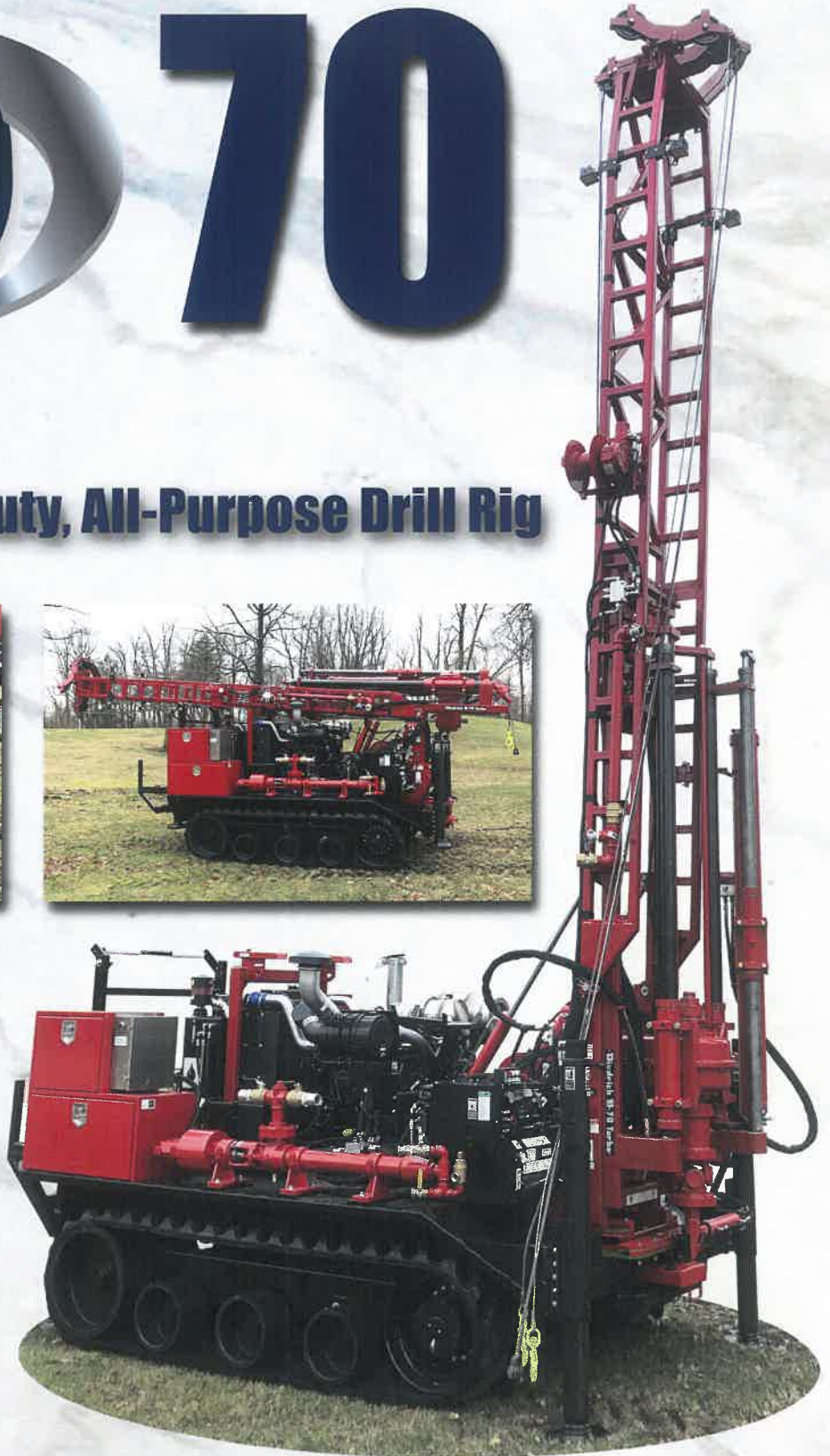

DIEDRICH DRILL

5 Fisher Street
LaPorte, Indiana 46350
Website: www.diedrichdrill.com

Phone: 800-348-8809
Local: 219-326-7788
Fax: 219-324-5962

Power Source:

John Deere, 4 Cylinder Turbo Diesel, Liquid Cooled
125 HP with Tier 4 Emissions

Maximum Gross Spindle Torque:

1st Gear
Up to 11,200 ft lbs.* (15,185 NM*)

Spindle Bore:

3 1/2" (89mm)

Push and Retract Force:

Up - 32,500 lbs. (145 kN)
Down - 21,450 lbs. (96 kN)

Maximum Spindle Speed:

1st Gear - 80 RPM*
6th Gear - 640 RPM*

Rotary Box:

#100, triple strand roller chain drive,
totally enclosed and running in oil

Clutch and Transmission:

13" (330 mm) clutch with heavy-duty helical gear
transmission with 6 forward gears and 1 reverse gear

Right Angle Drive:

Heavy-duty gear box totally enclosed and running in oil

Frame and Base:

The drill frame is a weldment constructed of heavy wall
rectangular steel tubing with sufficient strength and rigidity
for heavy duty use. The hydraulically operated sliding base
has 16" (406 mm) of forward/reverse travel and 6" (152 mm)
of side-to-side movement to provide clearance for hoisting
tools and can be mounted on any flat,adequate size surface.

* Optional High-Torque Rotary Box Available (13,612 ft lbs)



Specifications



Optional Equipment:**

- Mast and Control Panel Lighting
- Automatic SPT Hammer and/or Cathead Hoist
- Hydraulic Hoists - 800 lbs. Through 8,000 lbs.
- Water Pumps
- Rod Holder and/or Breakout Wrench
- Hydraulically Operated Chuck

** If you dont see an option you need, just ask!

***Weights and measurements are approximate and subject to change

Track Mount:***

- 7' 9" Width
- 21,700 lbs.
- 16" Ground Clearance
- 24" Track Width
- 5.25 PSI of Ground Pressure

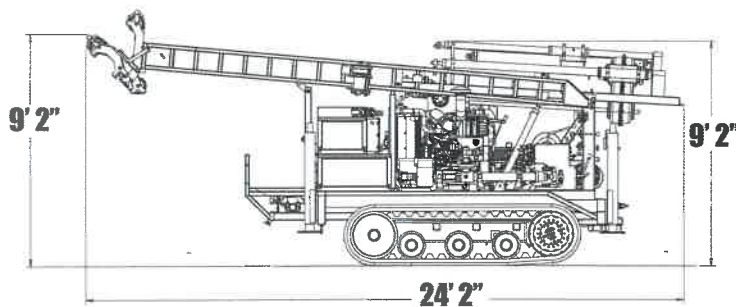

**Truck Mount and SBU Options
Available Upon Request**

Slide Base Up Width: 5'4"

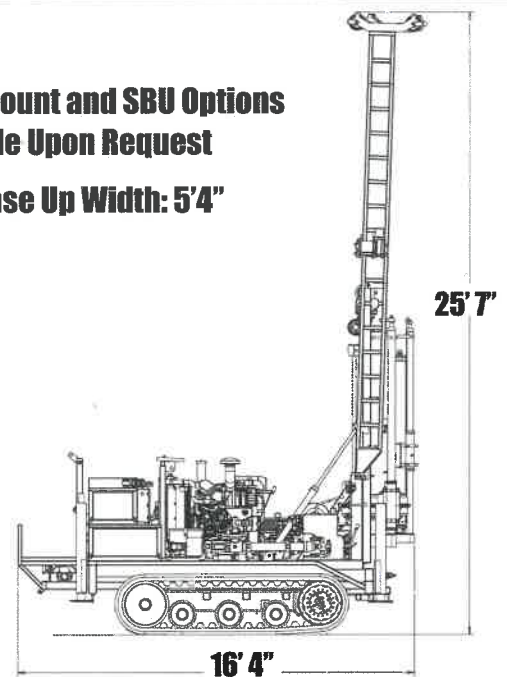

Rev. 11/2023



5 Fisher Street
LaPorte, Indiana 46350
Website: www.diedrichdrill.com

Phone: 800-348-8809
Local: 219-326-7788
Fax: 219-324-5962